



MIR

Design by:
Ludovica & Roberto Palomba

Year:
2007

The archetype of the mirror, a classic object updated by Ludovica and Roberto Palomba. The rigorous metal frame in painted metal is the swivel support to a long mirror. Perfect in narrow spaces or a corner thanks to the typical column-shape, Mir adapts to any context with its discreet and elegant presence, characterising a style marked by Lema's refined understatement.

TECHNICAL DRAWINGS

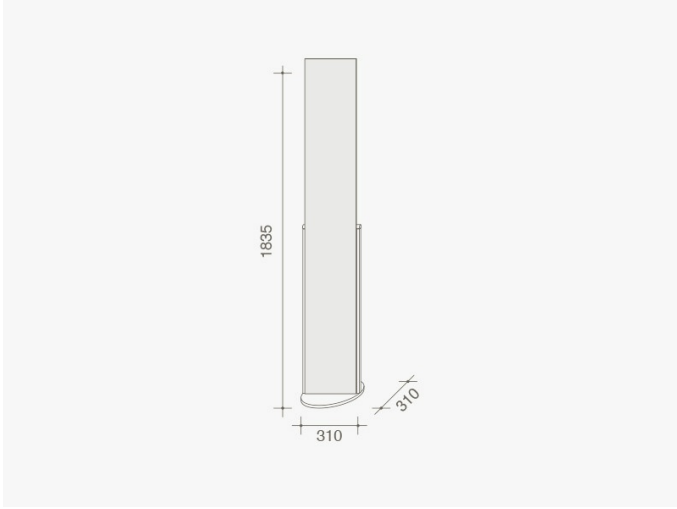

— *mir_01*